

User's Manual V1.41



Signal Generator Models APSIN, APGEN, APSYN

WARRANTY

All Anapico instruments are warranted against defects in material and workmanship for a period of two years from the date of shipment. AnaPico will, at its option, repair or replace products that prove to be defective during the warranty period, provided they are returned to Anapico and provided the preventative maintenance procedures are followed. Repairs necessitated by misuse of the product are not covered by this warranty. No other warranties are expressed or implied, including but not limited to implied warranties of merchantability and fitness for a particular purpose. Anapico is not liable for consequential damages. The warranty on the internal rechargeable batteries (option B3) is one year from the date of shipment. Battery replacement is available through Anapico and its distributors.

IMPORTANT! PLEASE READ CAREFULLY

Copyright

This manual is copyright by Anapico AG and all rights are reserved. No portion of this document may be reproduced, copied, transmitted, transcribed stored in a retrieval system, or translated in any form or by any means. Electronic, mechanical, magnetic, optical, chemical, manual or otherwise, without written permission of Anapico AG.

Table of Contents

TABLE OF CONTENTS	3
1 INTRODUCTION	5
1.1 WHAT DO YOU GET?	5
1.2 GENERAL FEATURES AND FUNCTIONS (MODEL OVERVIEW)	5
1.3 OPTIONS.....	6
1.4 FRONT PANEL OVERVIEW (APSIN MODELS ONLY).....	7
1.5 REAR PANEL CONNECTIONS	8
2 GETTING STARTED	10
2.1 SYSTEM REQUIREMENTS.....	10
2.2 UNPACKING THE INSTRUMENT.....	10
2.3 INITIAL INSPECTION	10
2.4 STARTING THE INSTRUMENT.....	10
2.4.1 <i>Applying Power</i>	10
2.4.2 <i>Connecting to LAN</i>	11
2.4.3 <i>Direct connectivity to host via Ethernet cable (no router)</i>	11
2.4.4 <i>Connecting through USBTMC</i>	11
2.4.5 <i>Installing the APSIN Remote Client</i>	11
2.4.6 <i>Troubleshooting the LAN Interconnection</i>	12
2.4.7 <i>Shutting Down the APSIN</i>	12
3 USING THE GRAPHICAL USER INTERFACE (GUI)	13
3.1 START THE APSIN GUI.....	13
3.2 THE COLTROL TAB.....	13
3.2.1 <i>Simultaneously controlling Multiple Signal Generators from one PC</i>	14
3.2.2 <i>Store and Load Instrument States</i>	15
3.2.3 <i>Setting Network Configuration</i>	15
3.2.4 <i>Setting the GPIB Address</i>	16
3.3 PERFORM FIRMWARE UPGRADE	16
3.4 USING TOOLBARS	16
3.5 BASIC CW OPERATION (CW TAB).....	17
3.6 SWEEPS	17
3.6.1 <i>Frequency Sweep</i>	18
3.6.2 <i>Power Sweep</i>	19
3.6.3 <i>List Sweeps</i>	19
3.7 MODULATION CONTROL	24
3.7.1 <i>Pulse Modulation</i>	24
3.7.2 <i>Pulse Train Modulation</i>	25
3.7.3 <i>Amplitude Modulation</i>	26
3.7.4 <i>Angle Modulation</i>	26
3.7.5 <i>Chirps</i>	27
3.8 REFERENCE IN AND OUT.....	28
3.8.1 <i>Bypass internal 100 MHz reference</i>	28
3.8.2 <i>Output Internal Reference</i>	29
3.9 USING THE TRIGGER OPTIONS (TRIGGER TAB)	29
3.10 LF OUT CONTROL	30
3.11 COMBINED MODULATION	32
4 LOCAL OPERATION VIA FRONT PANEL	33
4.1 DISPLAYED PARAMETER FORMATS	34
4.2 CW DISPLAY.....	34

4.2.1	<i>Main Menu Display</i>	34
4.2.2	<i>Frequency Sweep Submenu</i>	35
4.2.3	<i>Power Sweep Submenu</i>	36
4.2.4	<i>List Sweep Submenu</i>	38
4.3	MODULATION SUBMENU	39
4.3.1	<i>Pulse Modulation Submenu</i>	39
4.3.2	<i>Amplitude Modulation Submenu</i>	40
4.3.3	<i>Frequency Modulation Submenu</i>	40
4.3.4	<i>Phase Modulation Submenu</i>	41
4.4	REFERENCE SUBMENU	42
4.5	TRIGGER SUBMENU	42
4.6	LF OUTPUT SUBMENU	43
4.7	LAN CONFIGURATION SUBMENU	43
4.8	DISPLAY SETTINGS SUBMENU	44
4.9	SETTINGS SUBMENU	45
4.9.1	<i>Save Settings Submenu</i>	45
4.9.2	<i>Load Settings Submenu</i>	45
4.9.3	<i>Load Defaults Submenu</i>	46
4.10	HELP SUBMENU	46
5	REMOTE PROGRAMMING THE APSIN	48
6	BATTERY OPERATION (B3 OPTION)	49
7	EXTENDED POWER RANGE (PE3 OPTIONS)	52
8	MAINTENANCE AND WARRANTY INFORMATION	53
8.1	ADJUSTMENTS AND CALIBRATION	53
8.2	REPAIR	53
8.3	SAFETY	53
8.4	WARRANTY INFORMATION	53
8.5	EQUIPMENT RETURNS	54

1 Introduction

This instruction manual is valid for Anapico model series APSIN, APGEN, and APSYN. Chapter 2 gives you guidance for a quick and easy setup of your new instrument. Chapter 3 describes the remote operation via Anapico graphical user interface (GUI). Chapter 4 describes control via front panel and applies only to APSIN models.

1.1 What do you get?

Your signal generator kit contains the following items:

- Mainframe
- Universal power adaptor (AC 100 – 240V) with corresponding CH, UK, US, EU plugs
- Ethernet Cable
- Manuals & software CD

It is strongly recommended to use the original power adaptor (as supplied in this package) to guarantee save and reliable operation of your instrument.

1.2 General Features and Functions (Model overview)

Anapico RF & Microwave Signal Generator model overview

Models	Range	Power range	Options	Display
APSIN2010	9 kHz – 2 GHz	-30 - +15 dBm	B3, PE3, GPIB, RM	Y
APSIN4010	9 kHz – 4 GHz	-30 - +15 dBm	B3, PE3, GPIB, RM	Y
APSIN6010	9 kHz – 6.1 GHz	-30 - +15 dBm	B3, PE3, GPIB, RM, AVIO	Y
APSIN12G	100 kHz – 12 GHz	-20 - +15 dBm	B3, PE3, GPIB, RM	Y
APSIN20G	100 kHz – 20.4 GHz	-20 - +15 dBm	B3, PE3, GPIB, RM	Y
APSIN26G	100 kHz – 26.5 GHz	-15 - +25 dBm	B3, PE3, GPIB, RM	Y
APGEN3000	9 kHz – 3 GHz	-65 - +13 dBm	-	N (opt)
APSYN420	0.65 GHz – 20.4 GHz	+15 dBm	-	N

General features include

- Extendable power range (option PE3)
- Modulation capabilities for FM, PM, AM and PULM modulation (model dependant)
- Fast frequency, power and list sweeps
- Light weight, optional internal rechargeable batteries (option B3)
- 3- inch status LCD (APSIN models only)

- Long-term support: Software upgrades (firmware, API, GUI) are available to download from www.anapico.com. You can also call our technical specialists for support. You can continue to use both of these services free of charge for the lifetime of the product.
- Universal LAN VXI-11 and USB 2.0 device and host interface
- 18-24 months calibration cycle

1.3 Options

B3: internal rechargeable battery

FS: fast switching

PE3: mechanical step attenuator for extended power range

APSIN4010, APSIN6010	90 dB
-----------------------------	--------------

APSIN20G, APSIN26G	75 dB
---------------------------	--------------

GPIB: GPIB interface added

AVIO: specific avionics modulation capabilities added

1URM: 19" 1HE enclosure

1.4 Front Panel Overview (APSIN models only)

The front panel contains a status display, RF output female N-type connector (APSIN4010, APSIN6010) or a female SMA connector (APSIN12G, APSIN20G, APSIN26G), and a RF on/off key (Figure 1-a). The LCD screen shows information on the current function. Information includes status indicators, frequency and amplitude settings, current connectivity status, and error messages. Five control buttons allow easy menu control.



Figure 1-a APSIN Front Panel View (Model APSIN20G)

RF On/Off button The **ON/OFF** key toggles between RF output on and RF output off. The green light (*) is indicating whether the RF output is enabled (light on) or disabled (light off).

RF 50 Ω connector This female N- type respectively SMA connector provides the output for generator signals. The impedance is 50 ohm. The reverse power damage level is +30 dBm maximum. The maximum allowed DC level is +/- 10 V. Please check the data sheets for more details.

Main LCD display The main display shows the following information:

- 1st line: RF frequency in Hz
- 2nd line: RF amplitude in dBm
- 3rd line: Frequency reference status (internal, external, lock status)
- 4th line: Remote control status

1.5 Rear Panel Connections

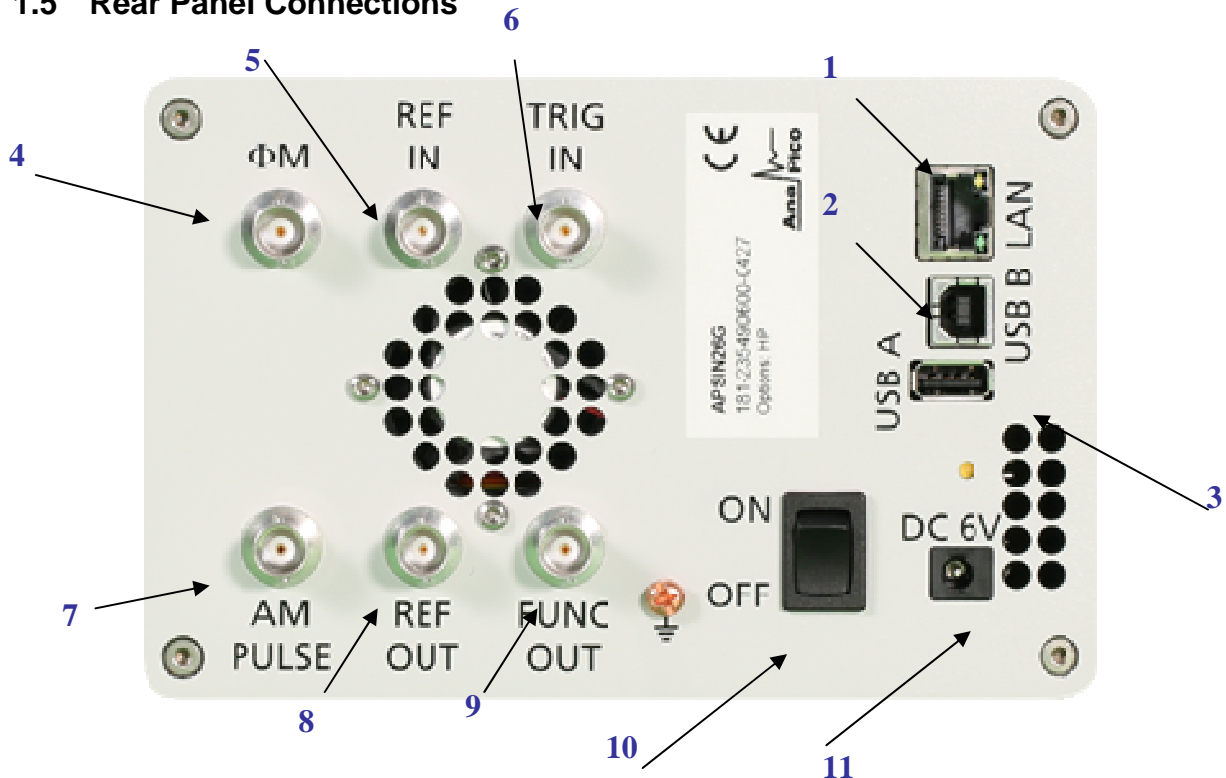

Figure 2 APSIN Rear Panel View

1 RJ-45 host connector Used for connecting with a controller such as PC or Laptop.

2 USB Device Used for connecting with a controller (PC, laptop). Communication via USB-TMC protocol.

3 USB Host Used for connecting USB devices such as Memory sticks or USB-TMC power meters. Check with factory for list of supported devices.

4 Phase MOD IN connector This BNC input connector accepts 0 to 2 V (peak) signal for frequency and phase modulation. The damage level is 4 Vrms.

5 REF IN connector Female BNC connector accepts a TTL or -5 to +15 dBm sine signal from an external reference oscillator that is within ± 1 ppm of the programmed reference frequency. The nominal input impedance is 50 ohm.

6 TRIG IN connector Female BNC connector accepts TTL signal from an external trigger source. The input impedance is 1Mohm.

7 AM / PULSE MOD IN connector This BNC input connector accepts TTL signal for pulse modulation respectively analogue voltage for AM. The damage level is 5 Vrms.

8 REF OUT connector Female BNC connector is for an output of the internal 10 or 100 MHz reference frequency which has a nominal output level greater than 0 dBm and an output impedance of 50 ohm.

9 FUNCT OUT connector Female BNC connector is used as a multiple purpose output. It can be programmed as trigger output, as video output during pulse modulation and as output for the low frequency function generator.

10 Power switch The power switch disconnects the signal generator from the DC input completely including the internal high-stability reference. After switching on this switch the signal generator enters into standby with the OCXO warming up and RF out switched off. The red power LED on the front panel is turned on.

11 DC IN power receptacle The power receptacle accepts two-pin plug from the external 6 V DC power adapter.

2 Getting Started

2.1 System Requirements

The Anapico graphical user interface requires at least the minimum system requirements to run one of the supported operating systems.

Operating system	Windows™ 2000 SP4, XP SP2, Vista, 7, 8
Remote	10/100/1000M Ethernet or USB 2.0 Port

2.2 Unpacking the Instrument

Remove the instrument materials from the shipping containers. Save the containers for future use.

The standard product package includes:

- 1 Synthesized Signal Generator*
- 1 Ethernet Cable*
- 1 Universal DC power adapter*
- 1 Software & Manual CD*

2.3 Initial Inspection

Inspect the shipping container for damage. If container is damaged, retain it until contents of the shipment have been verified against the packing list and instruments have been inspected for mechanical and electrical operation.

2.4 Starting the Instrument

This section describes installation instructions and verification tests.

2.4.1 Applying Power

Place the instrument on the intended workbench and connect the appropriate DC power supply to the receptacle on the rear of the unit. Make sure you use the included DC power supply. The instruments typically require 6 V DC at 3A peak. **Using other supplies may lead to malfunction and damage of the Instrument.**

Press the line on/off switch on the rear panel. If available, the front panel display will illuminate. The instrument will initialize and momentarily display the model number, firmware revision and product serial number. The display will then switch to the factory default display setting, showing preset frequency (100 MHz) and power (0.0 dBm), phase lock status (of internal reference) and instrument connectivity status (Ethernet IP or USB identifier).

Note, the instrument booting process may take up to 60 seconds (depending on configuration) to complete.

2.4.2 Connecting to LAN

Connect the instrument to your local area network (LAN) using the Ethernet cable. By default the instrument is configured to accept its dynamic IP number from the DHCP server of your network. If it is configured properly, your network router will assign a dynamic IP number to the instrument which will be automatically displayed on the screen. Your instrument is now ready to receive remote commands.

2.4.3 Direct connectivity to host via Ethernet cable (no router)

You can connect to the instrument to your computer with the Ethernet cable without using a local area network with DHCP server. To work properly, the network controller (NIC) of your computer must be set to a **fixed IP beginning with 169.254.xxx.xxx** (excluding 169.254.1.0 and 169.254.254.255) and network mask 255.255.0.0 to match the fallback IP that the APPH will assign itself after network timeout. The APPH will automatically choose an IP address according to **ZEROCNF** standard. Therefore, the exact fallback address can't be predicted.

Connection from a NIC that is configured to use DHCP is also possible. After a preset timeout, the NIC will assume that no DHCP is available and self-assign a fallback IP that will fall into the range 169.254.xxx.xxx.

Alternatively, you may assign the instrument a fixed IP. Please refer to a later section of this manual to learn how to do this.

2.4.4 Connecting though USBTMC

Connect the (powered on) instrument to the computer using the USB cable. If properly connected, the computer host should automatically recognize your instrument as a USBTMC device.

Note if you want to work with the Anapico GUI, it must be installed with USB support selected. Then the GUI will detect all attached devices automatically. Open the GUI and follow the instructions given in Chapter 4.

Alternatively, a VISA runtime environment (NI or Agilent or comparable) must be installed.

Use VISA Write to send the *IDN? Query and use VISA Read to get the response. The USBTMC protocol supports service request, triggers and other GPIB specific operations.

2.4.5 Installing the APSIN Remote Client

Anapico's graphical user interface provides an intuitive control of the instruments. It runs under Windows™ operating system with minimum requirements. The DLL is embedded in the GUI application and requires the Microsoft® .NET™ framework to be installed. To install the GUI on the computer, insert the Anapico Software and Manual CD into the CD/DVD drive. If the setup doesn't start automatically double click on the **setup.exe** to run the auto-installer.

The self-extracting setup provides easy installation and de-installation of the software. The setup program guides you in a few steps though the installation process. In case the NET framework is not

installed on your current Windows™ operating system, the setup procedure will assist you automatically to install the required version. For this you will need an active internet connection.

2.4.6 Troubleshooting the LAN Interconnection

Software does not install properly

- Make sure your installation CD is not damaged.
- When Microsoft .NET Framework is not installed make sure that your computer is connected to the internet during installation of the Anapico Software. If no internet connection is available, install the .NET™ Framework that is available on the installation CD.

Software cannot detect any instrument

- Make sure you have connected both computer and instrument to a common network.
- If a direct connection is used you may require to reset your computer Ethernet controller (depending on the configuration). Note that in that case detection of the instrument can take a considerable amount of time if your computer is configured to work with an external DHCP server. In some cases the detection may even fail completely. Configure your computer network controller to an appropriate fixed IP instead.
- Make sure that your software firewall enables the GUI to setup a TCP/IP connection via the LAN. Under Windows XP you can do that like this:
Open *Control Panel* under *Settings* in your *Start* menu. Then go to *Windows Firewall*. Click on *Exceptions* and then *add Program*. If the GUI is in this list, choose it and click *OK* otherwise you have to browse for the path to GUI installation directory. Finally close all open dialogs with *OK*. Now your Windows™ Firewall will not block requests from the GUI.

2.4.7 Shutting Down the APSIN

Press the line on/off switch on the rear panel to off.

3 Using the Graphical User Interface (GUI)

Anapico's graphical user interface provides an intuitive control of the signal generator. It runs under any Windows™ operating system. Make sure the software is installed correctly and the computer's firewall is configured properly. The GUI's dynamic link library (DLL) uses the Microsoft .NET framework.

3.1 Start the APSIN GUI

After successful installation of the software double-click the software shortcut that has been created on your desktop.

After start the GUI will automatically detect existing Anapico instruments that are connected to the computer (network) via local area network, USB, or GPIB. In the **CONTROL** tab (see Figure 3-a) the detected instruments are listed. Clicking on one of the devices will instantly establish connection. Clicking on an alternate device will disconnect the old device and reconnect to the new device. **Scan Instruments button** will enable automated scanning for new instruments. **Disconnect/Connect button** will establish and terminate connection.

3.2 The COLTROL Tab

The CONTROL tab (Figure 3-a) completes the following function

- Scan and establish connection to instrument
- Configure remote interface (LAN, USB, GPIB)
- Save, load and manage instrument memory states



Figure 3-a CONTROL Tab

3.2.1 Simultaneously controlling Multiple Signal Generators from one PC

You can easily control multiple Anapico instruments from a single computer but you need to start a separate GUI for every instrument as only one instrument is controlled by the GUI at once.

3.2.2 Store and Load Instrument States

Multiple different memory states are available to store instant instrument settings. By clicking on the **Device Settings Memory** button the currently saved memory settings are displayed and can be

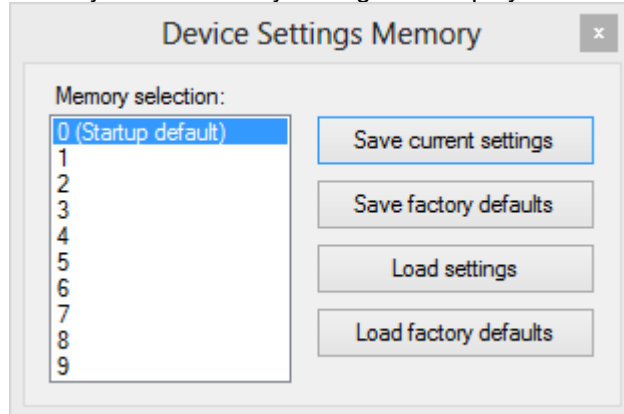

loaded or overwritten as shown in Figure 3-b. To modify or enter a state, click on the appropriate line and select if the current instrument settings shall be stored in or loaded from the selected memory state.

NOTE: Memory 0 is used as default state when the instrument is powered up.

The memory states can also be accessed via the front panel menu.

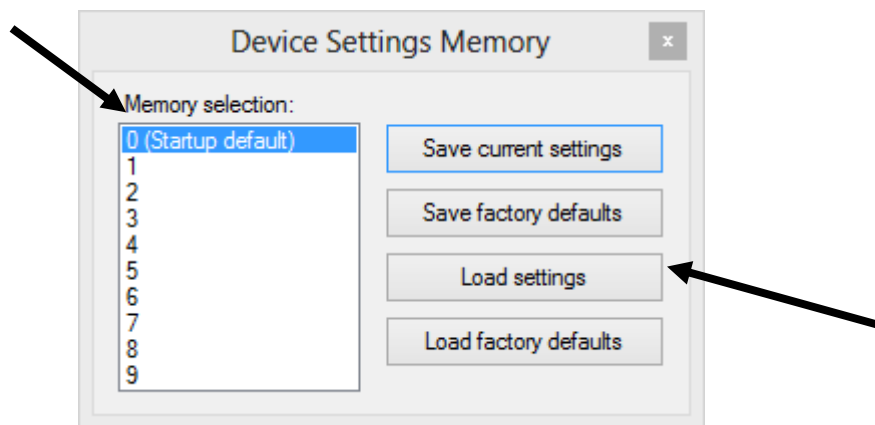

Figure 3-b Memory Settings Submenu

3.2.3 Setting Network Configuration

If your network does not have a DHCP server or a static IP address is preferred you can set an IP address, network mask and default route. The address and mask settings are required. The default route is not strictly necessary but enables network communication between the test set and devices on a subnet other than that to which it is immediately attached. The network features can be used on the local area network even if no default route (specified as 0.0.0.0) is configured.

The **Network Configuration** button allows configuring the LAN settings as shown in Figure 3-c.

Using a DHCP (dynamic host configuration protocol) server can be enabled or a static IP can be entered by user. The device name can be modified as desired. The unit serial number and firmware revision are displayed on the bottom.

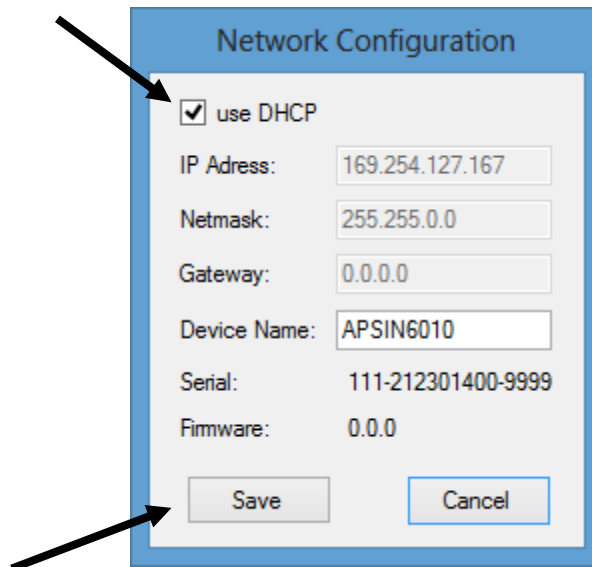

Figure 3-c Network Configuration Submenu

3.2.4 Setting the GPIB Address

If the instrument has the GPIB option installed, the GPIB address can be changed in the GPIB submenu in the control tab. Valid GPIB address is 1 to 30.

To verify GPIB functionality, use the VISA Assistant available with the Agilent IO Library or the Getting Started Wizard available with the National Instrument IO Library. These utility programs enable you to communicate with the signal generator and verify its operation over GPIB. For information and instructions on running these programs refer to the Help menu available in each utility.



3.3 Perform Firmware Upgrade





A firmware upgrade of the instrument can be done directly via the GUI. First make sure you are connected to the right instrument and have the correct firmware binary file (.rar) ready. Then apply **Controller → Update Firmware** and select the appropriate binary file that you have received from Anapico or downloaded from the Anapico website. The update will take a few seconds and after completion your instrument will reboot. Reconnect to the instruments after booting is completed and continue with the updated firmware. **NOTE: Do not disconnect and power off device during firmware update is in process.**

3.4 Using Toolbars

In the existing GUI Version there are two Toolbars available.

The standard toolbar looks like:  with the following symbol functionality:

-  Close the Application
-  Connect / Disconnect

-  Save to Memory
-  Network Configuration
-  Reset System
-  Restart Controller

3.5 Basic CW Operation (CW tab)

Anapico signal generators are laboratory instruments designed to generate a synthesized CW signal with good spectral purity and fixed or variable amplitude. To set a desired frequency, relative phase and amplitude, click to the **CW tab** (Figure 3-d). The desired frequency, phase and power can be set by clicking on the up and down arrows above and below each digit. The frequency is settable in steps of 0.001 Hz, the phase is settable in steps of 0.1 degrees and the power in steps of 0.01 dB.

The **RF ON/OFF button** turns the RF power on and off. The green LED in the RF ON button indicates that the RF output is enabled. The **MOD ON/OFF button** allows instant enabling (disabling) of a previously enabled modulation.

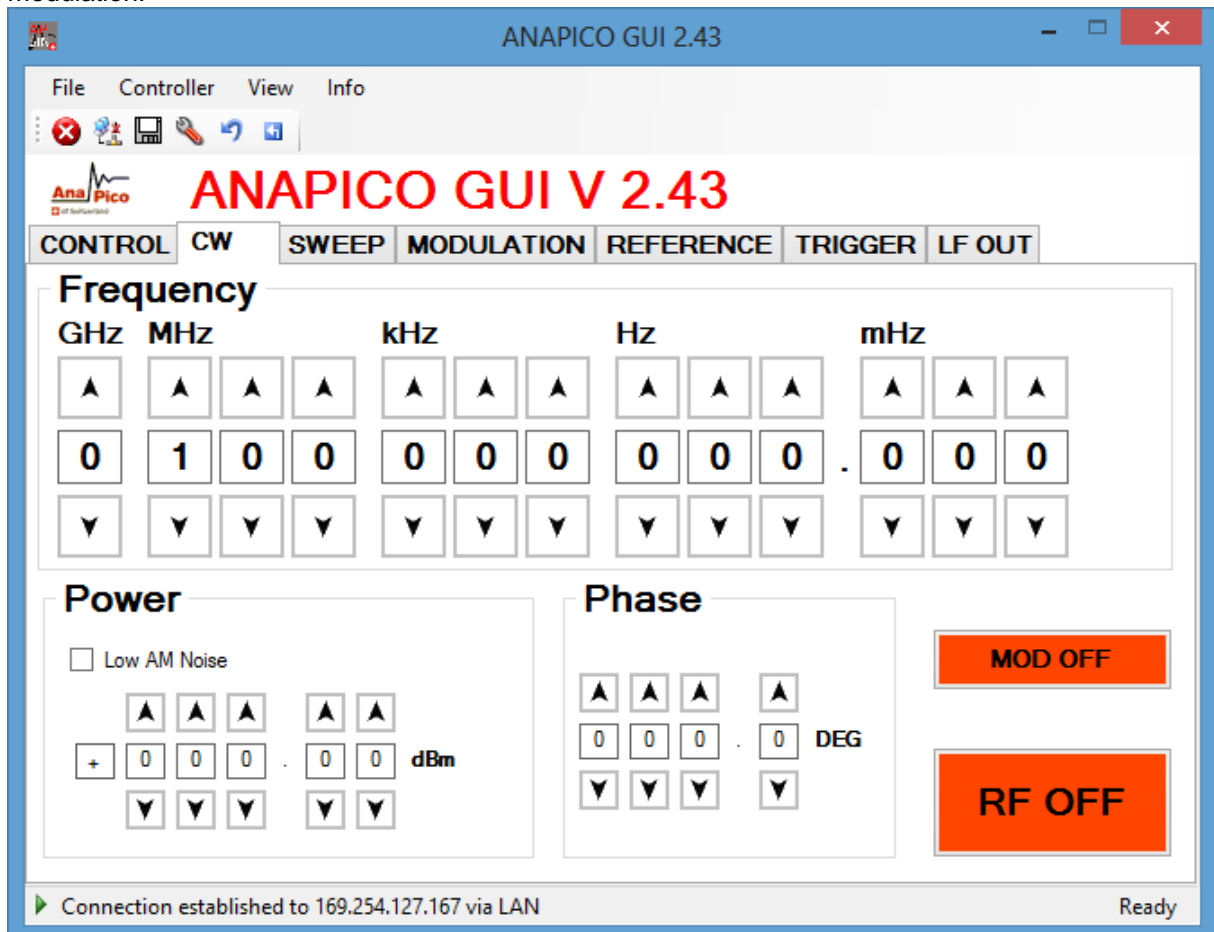

Figure 3-d CW Tab

3.6 Sweeps

Besides the basic CW operation, the instrument supports several sweeping modes. Sweep parameters can be set in the **SWEEP tab** (Figure 3-e). Select frequency, power or list sweep by clicking on the **FREQ. SWEEP**, **POWER SWEEP** or **LIST SWEEP tab** respectively.

3.6.1 Frequency Sweep

To start a frequency sweep,

- a) enter start and stop frequency in Hz unit
- b) enter the number of points (or points per decade)
- c) enter the dwell time in milliseconds (min. dwell time is 50 microseconds)
- d) enter the off time in microseconds
- e) select the sweep mode as linear or log; additionally click “random” if random sequence is desired
- f) select the repetition mode: enter number of repetitions or choose “infinite”
- g) select the ALC mode: on hold or off. Generally ALC on is used. If very short dwell times (1-2 ms) are needed, the ALC can be set to “hold”. In this way the ALC loop is disabled during the sweep. The ALC voltages are calibrated before the sweep to maintain high level accuracy during the sweep
- h) press the on/off button

The time resolution is 200 ns. Note that the sum of the dwell time and the off time must be greater or equal to 1.0 ms. The dwell time must be at least 50 μ s. The off time can be also be 0 (no off time).

When “auto” is selected, the off time is automatically adjusted such that during switching transients the output is disabled and the sum of dwell and off time are at least 1.0 ms.

Under “repetition mode” you can select how many times the sweep should be executed by entering 1 to N times or select infinite. Selecting “Rand” will sweep the frequencies in a random manner until terminated by user. In all cases the frequency returns to the CW frequency as soon as the sweep is terminated.

Start and stop the sweep by pressing the **ON/OFF button**.

The switching transient between frequency steps depends on the step size and if internal bands of the synthesizer are crossed. Typical switching transients are <10 μ s for a <100 MHz step (no band crossing) and <50 μ s for arbitrary steps at output frequencies.

3.6.1.1 Frequency Linear Sweep

This mode sweeps linearly from start to stop frequency in constant steps. Frequency step size is $(f_{\text{stop}} - f_{\text{start}}) / \text{number_of_points}$.

If start < stop then negative frequency steps are performed.

3.6.1.2 Frequency Log Sweep

This mode sweeps logarithmically from start to stop frequency in a given number of points per decade.

3.6.1.3 Frequency Random Sweep

The output frequency is selected randomly between start and stop frequency. The number of different output frequencies is determined by the number of points selected by the user.

3.6.2 Power Sweep

To run a power sweep, enter start and stop power in dBm unit, the number of steps, dwell and off time in milliseconds. When “auto” is selected, the off time is automatically adjusted such that during switching transients the output is disabled and the sum of dwell and off time are at least 400 μ s. Select if the sweep should run a predefined number of times (enter desired number) or infinite times (selecting infinite). Select ALC settings. Start and stop the sweep by pressing **ON/OFF button**.



Figure 3-e *FREQUENCY SWEEP Tab*

3.6.3 List Sweeps

List sweeps allow to set frequency, output power, dwell time and off time for each entry individually. To start a list sweep, the following steps are required:

- select sweep parameter
- select indexing
- upload list file from computer (CSV-file) or load sweep from instrument flash memory or edit new list
- select number of repetition
- select ALC mode: on, hold or off. Generally ALC on is used. If very short dwell times (< 2 ms) are needed, the ALC can be set to “hold”. This way the ALC loop is disabled during the

sweep. The ALC voltages are calibrated before the sweep to maintain high level accuracy during the sweep

- f) start sweep with on/off button



Figure 3-f POWER SWEEP Tab

Select parameter to sweep: frequency, power or both. If only one parameter is selected to sweep, the second parameter is set to the first value (line 1 of the CSV file) for the duration of the sweep.

Choose the direction of the sweep: to go up, down or be random. If you select random indexing, the index is randomly chosen for N times where N is the number of list points.

3.6.3.1 Sweep File Format

The input file must be a 4 column CSV file with the following syntax on each line:

frequency [in Hz] ; power [in dBm] ; dwell time [in μ s] ; off time [in μ s]

Note the four entries in each line **must be separated by a semicolon**.

Figure 3-h shows a valid list file with four points displayed in Microsoft Excel. Each line describes one list point. The first line must contain all for entries, in any other line entries may be omitted. Lists may contain up to **10'000 lines**.

The off time may be set to zero if the output is not to be disabled during transients. The sum of dwell time and off time must comply with the minimum and maximum values specified in the data sheet of the instrument. Transient times depend on the frequency steps and are typically less than 10 μs for a 100 MHz step.

The number of repetitions determines how many times the complete list will be executed.

List sweeps can be directly loaded, edited and saved from the GUI. Press the List Memory button in the List Sweep Tab to open the list sweep editor as shown in Figure 3-i.



Figure 3-g LIST SWEEP Tab

	A	B	C	D	E
1	2400000000	10	2500	500	
2	2420000000	5.5	2500	500	
3	2440000000	10	2500	500	
4	2460000000	-15.5	2500	500	
5					
6					
7					
8					

Figure 3-h CSV-file with four points (1st column: frequency in Hz, 2nd: power in dBm, 3rd: dwell time in μ s, 4th: off time in μ s).NOTE: values must be separated by semicolon!

3.6.3.2 List Sweep Editor

The list sweep editor consists of a table editor on the right and the save and load functions on the left (see Figure 3-i).

To create a new list, just enter the various frequency and power values in line 1 to N. You can also load an existing list sweep file (in CSV format) from the computer by using the Open list file button below.

After you have completed the list sweep you can save the list either on your computer (Save list file button) or load it to the instrument (\leftarrow Send button). Once loaded to the instrument, the list is the active list in the memory. To save the active list in the non-volatile memory of the instrument you enter a filename and press the \downarrow Store button.

If you want to locally edit an already stored list, sweep from the instrument, select the respective list sweep file (or memory) and press the \rightarrow Get button.

The list sweep that shall be executed must be loaded into the Device list RAM by using the \leftarrow Send or \uparrow Load buttons.

Confirm your selection with "OK" to return to the List Sweep Tab and start the sweep with ON/OFF button.

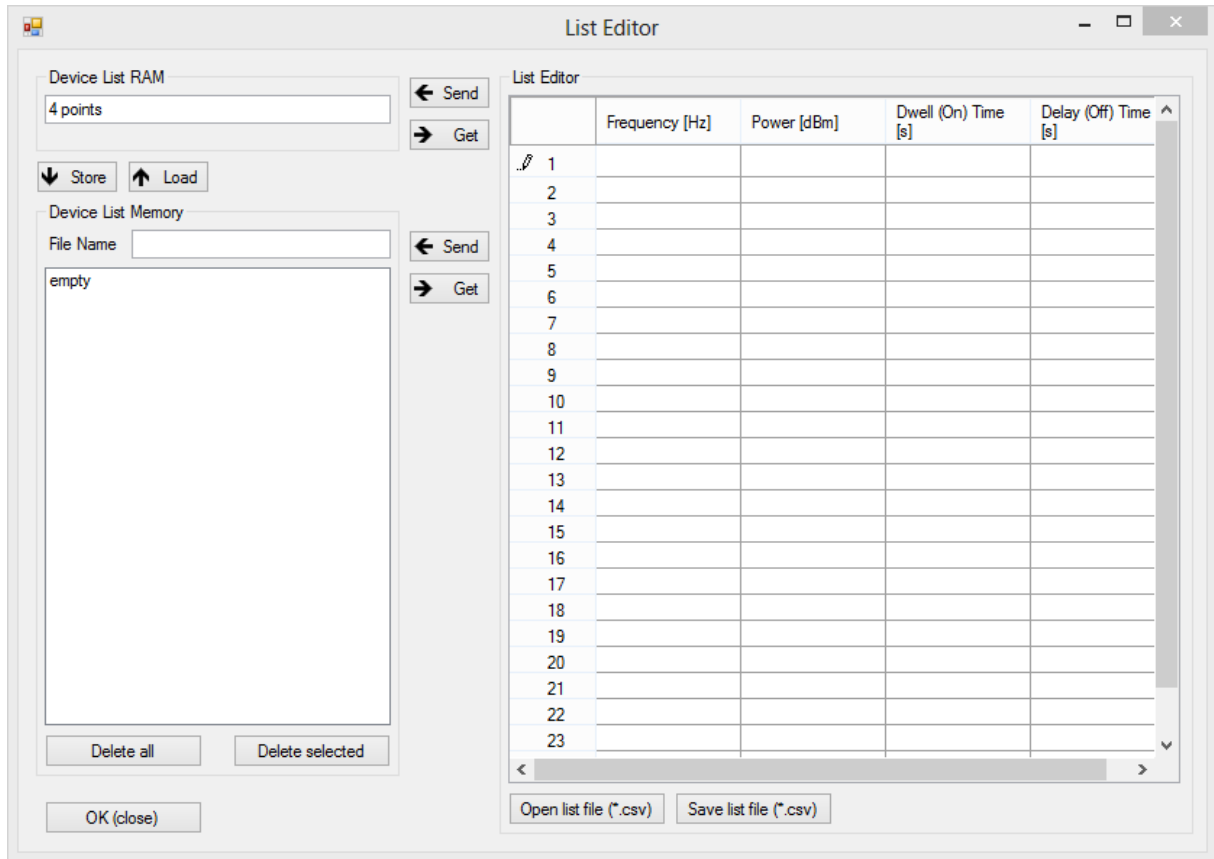

Figure 3-i List Editor

3.7 Modulation Control

The instrument provides various modulation capabilities that can be accessed by the **MODULATION Tabs** (Figure 3-j). The modulation capabilities depend on the particular instrument model and are enabled by the GUI correspondingly.

3.7.1 Pulse Modulation

Select Mode as “Pulse Modulation”

On the left the internal pulse modulation can be preset and started with the ON/OFF button. For internal pulse modulation, select pulse width and modulation period in milliseconds. Note that pulse width resolution and accuracy is approx. ± 15 ns.

For external modulation change the “Source” to “External Pulse”.

For both, internal and external, the “Inverse Polarity” button allows the instant inversion of the modulation polarity.



Figure 3-j PULSE Tab

3.7.2 Pulse Train Modulation

Define pulse train sequences by using the pulse train editor (Figure 3-k).

Select Mode as “Pulse Trains”.

The editor becomes available when mode is set to pulse trains. There are two input options:

Hexadecimal string or select/unselect boxes of the binary representation. The maximal sequence length is 256 bits or 64 (hexadecimal) chars when using the GUI. Via direct remote programming up to 4096 bits can be programmed.

The pulse width and pulse period can be set in ranges of milliseconds or microseconds and selected by the button next to the digits (Figure 3-j).

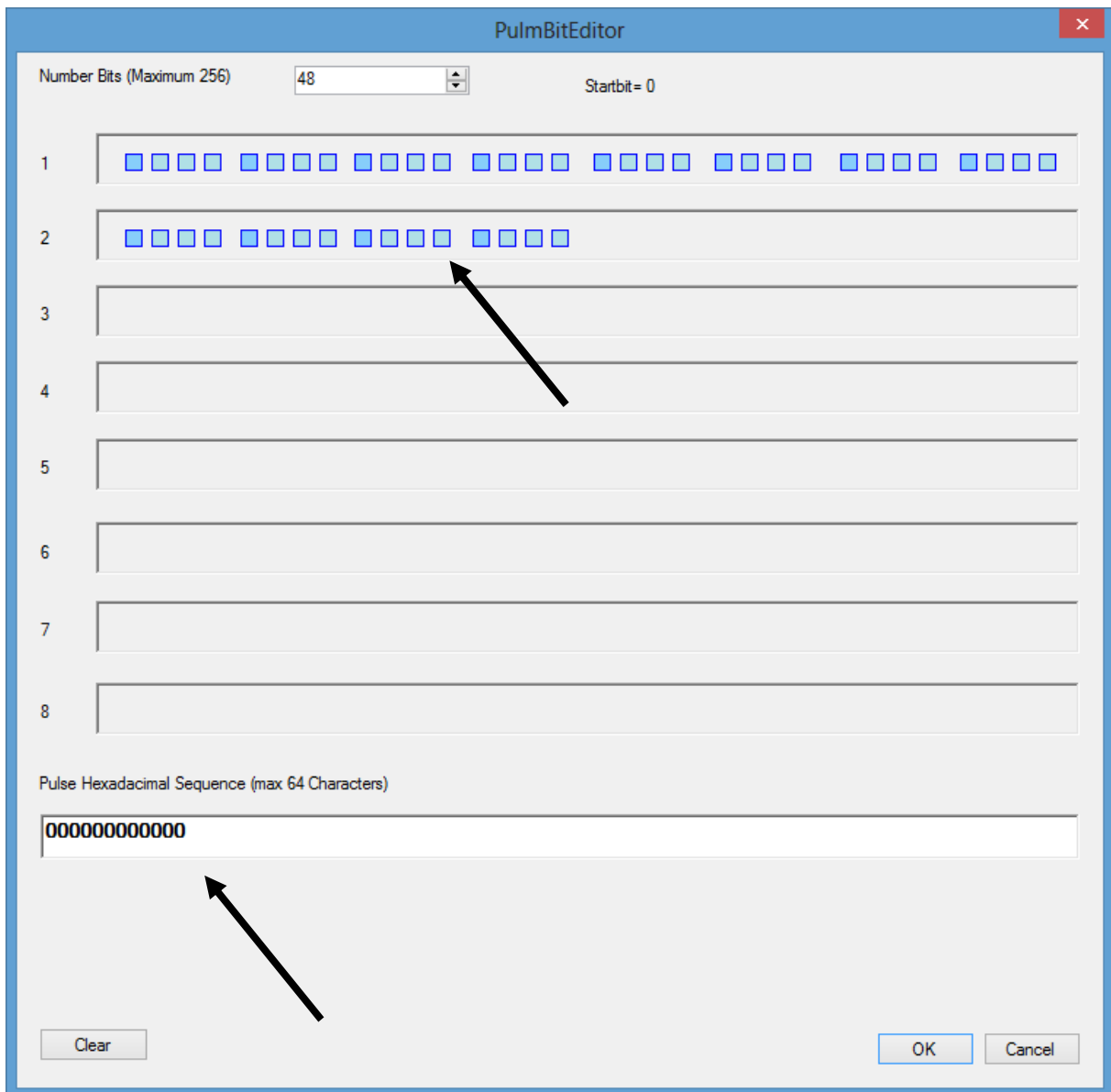

Figure 3-k Editor for Pulse Trains

3.7.3 Amplitude Modulation

The internal amplitude modulation (Figure 3-l) can be enabled by pressing the ON/OFF button in the AM submenu. For internal modulation, the modulation depth and rate can be set. The internal function generator is used to provide the modulation signal. The shape can be set to sine or square. Switching between internal and external amplitude modulation is possible.

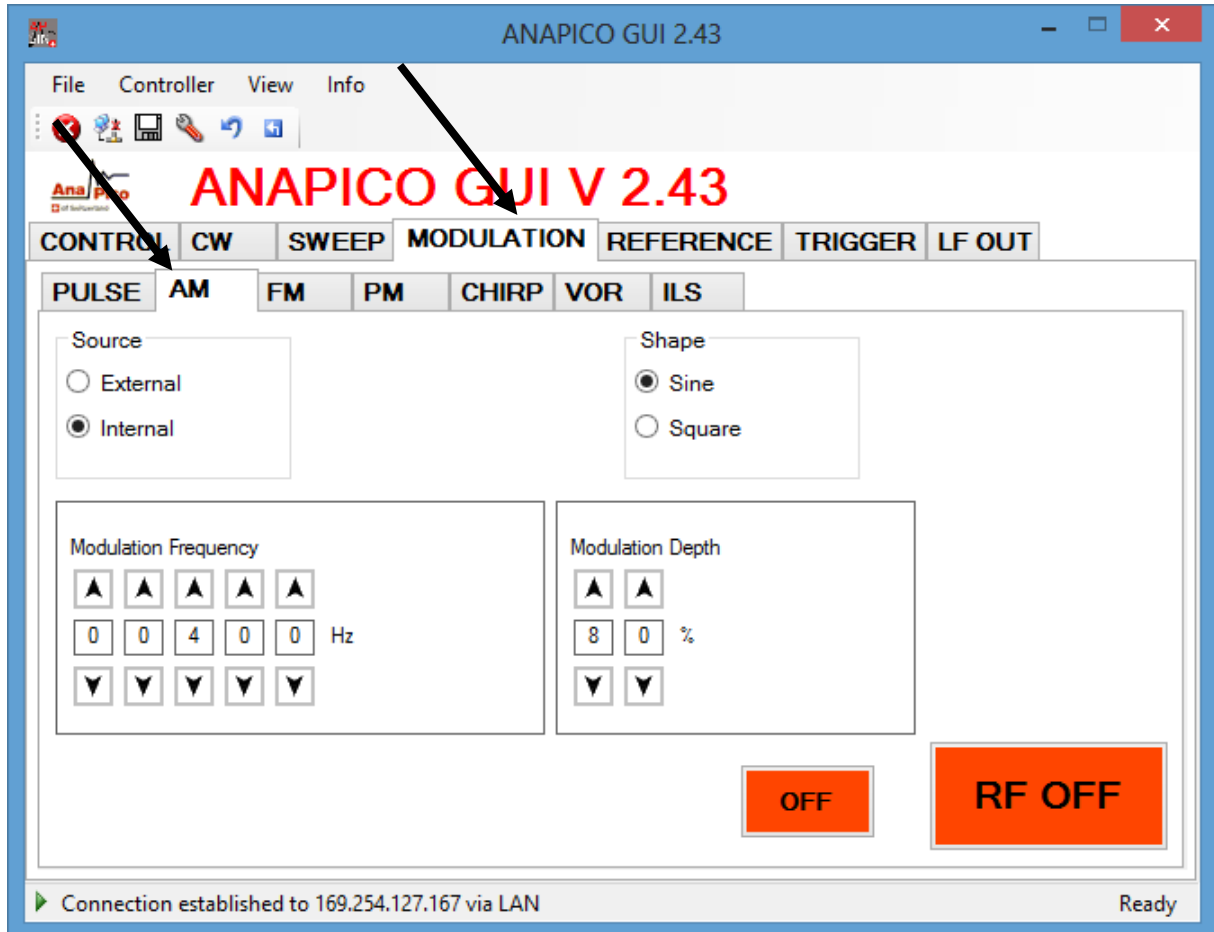

Figure 3-l AM Tab

3.7.4 Angle Modulation

The frequency and phase modulation settings can be accessed by selecting respective FM (frequency modulation) or PM (phase modulation) tabs (Figure 3-m). AC or DC coupling can be selected.

For external angle modulation, enter the desired sensitivity per Volt for either frequency or phase modulation and press the ON/OFF button to enable (disable) the modulation. Connect the modulation source to the rear BNC input.

For internal modulation, the modulation rate and deviation can be set as well as the modulation waveform (Sine, Ramp, Triangle, Square).

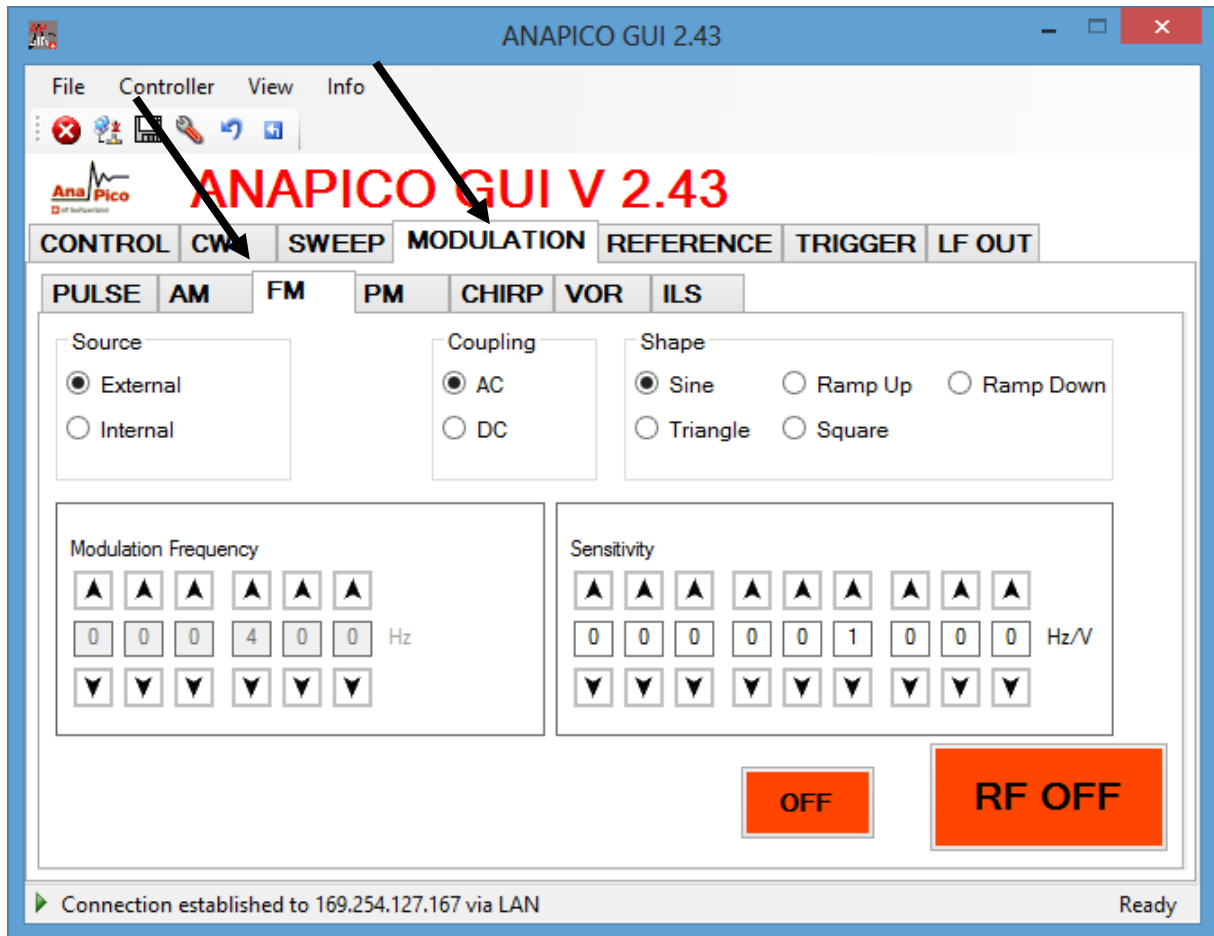

Figure 3-m FM Tab

3.7.5 Chirps

Specify centre frequency and frequency-span for running chirps (see Figure 3-n). For the chirp-time the units can be set to milliseconds or microseconds by the button next to the digits.

The chirp sweep direction is either up, down or bidirectional (up first or down first).

The repetitions can be set from 1 to infinity. Note: Enable the sweep with the ON/OFF button.

To effectively start the chirp the trigger system must be appropriately set on the trigger tab.



Figure 3-n CHIRPS Tab

3.8 Reference In and Out

The internal reference of the signal generator can be locked to an external frequency reference that is provided to the external reference input on the rear panel. To enable phase lock to the external reference go to the REFERENCE tab (Figure 3-o).

Click Use ext. reference and enter the frequency of the reference that has been externally applied.

The reference frequency must be specified within the frequency range and accurately set to at least 1 ppm. Note that the reference lock will fail if the frequency of the external reference is not accurately provided.

The lock status is shown as Locked (green) or Not Locked (red).

3.8.1 Bypass internal 100 MHz reference

Some instruments provide the option to bypass (disable) the internal reference and feed an external 100 MHz reference. To enable that operation mode select “External 100 MHz”.

3.8.2 Output Internal Reference

The internal reference can be output to one of the rear panel connectors. Enable the output by selecting the desired output frequency (10 or 100 MHz).

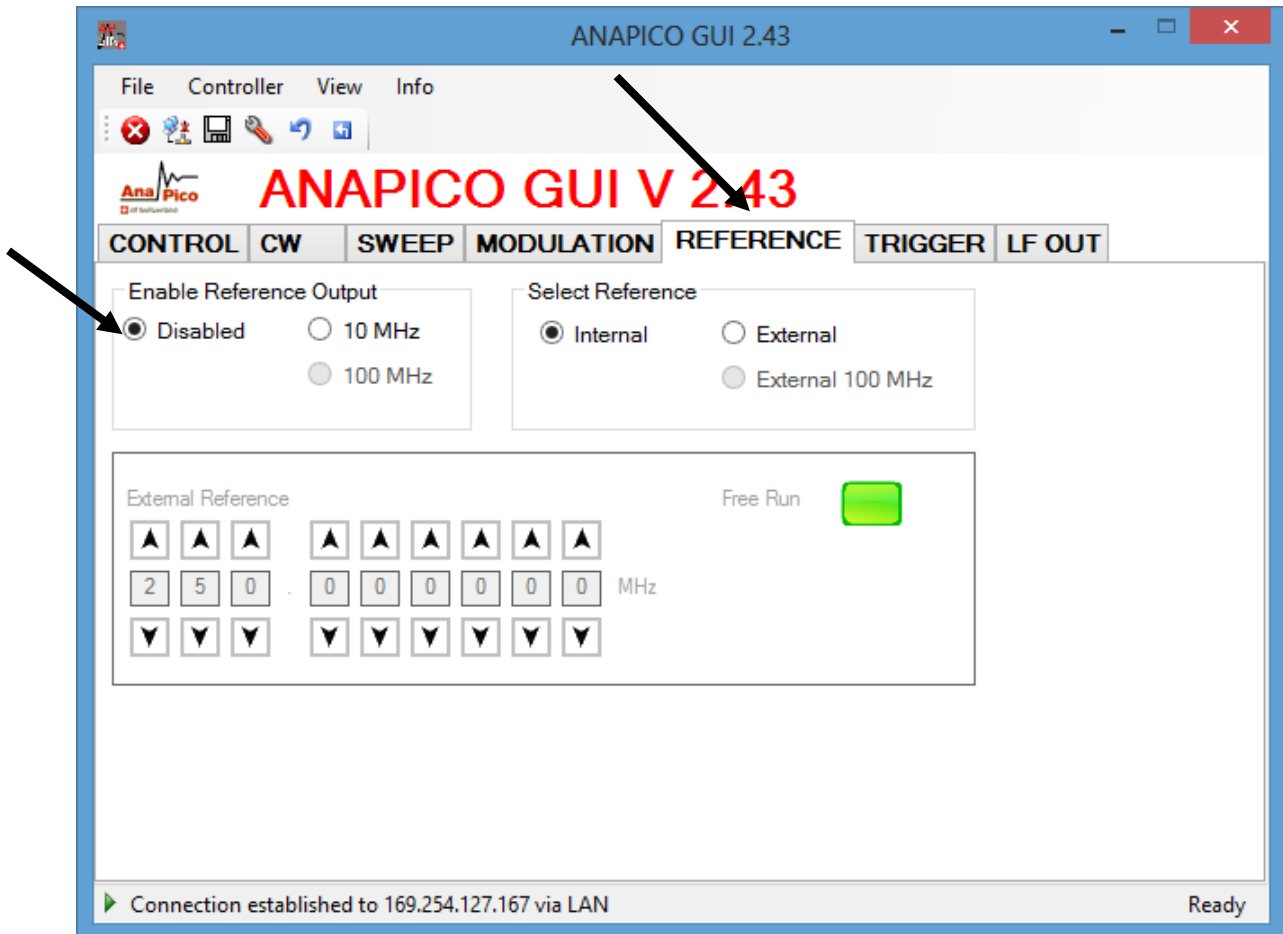

Figure 3-o REFERENCE Tab

3.9 Using the Trigger options (TRIGGER tab)

All instruments support internal and external triggering for frequency, power, list and chirp sweeps. To set the trigger options go to the **TRIGGER** tab as shown in Figure 3-p.

Various trigger sources are available:

- KEY** which is the **RF on/off button**
- LAN** (“soft trigger”, SCPI via LAN, USB, GPIB)
- external TRIGGER** at the rear panel (TRIG IN, TTL input)

The following trigger parameters can be defined:

- trigger delay**: 50 μ s to 10 sec in 1 μ s resolution predefined delay after trigger signal arrives. The trigger delay uncertainty is about $\pm 2 \mu$ s.
- trigger modulo**: N=1 to 255: defines every Nth trigger event to be used
- trigger active edge**: positive, negative and both (positive first or negative first)

- d) **trigger occurrence:** single event or repeated
- e) **trigger type:** single point, complete sweep or gated

Confirm settings and arm trigger by pressing the **Apply** button.

As soon as a sweep is programmed, the output is disabled while the trigger is expected. Upon arrival of the trigger, the sweep is executed (after given trigger delay). Any trigger signal arriving during execution of the sweep will be ignored.

If single sweep has been selected, the sweep will be executed only once as soon as first trigger signal arrives. As soon as the sweep is completed, the frequency will return to the preset CW frequency.

If repeat sweep is selected, the sweep will be executed every time the trigger signal arrives. After the sweep is completed, the frequency of the RF output is disabled until next trigger arrives.

With **trigger type**, the user can select the trigger either to execute only a single point from the sweep or the complete sweep. When **gated** is selected, the sweep is only executed while the trigger signal is high.

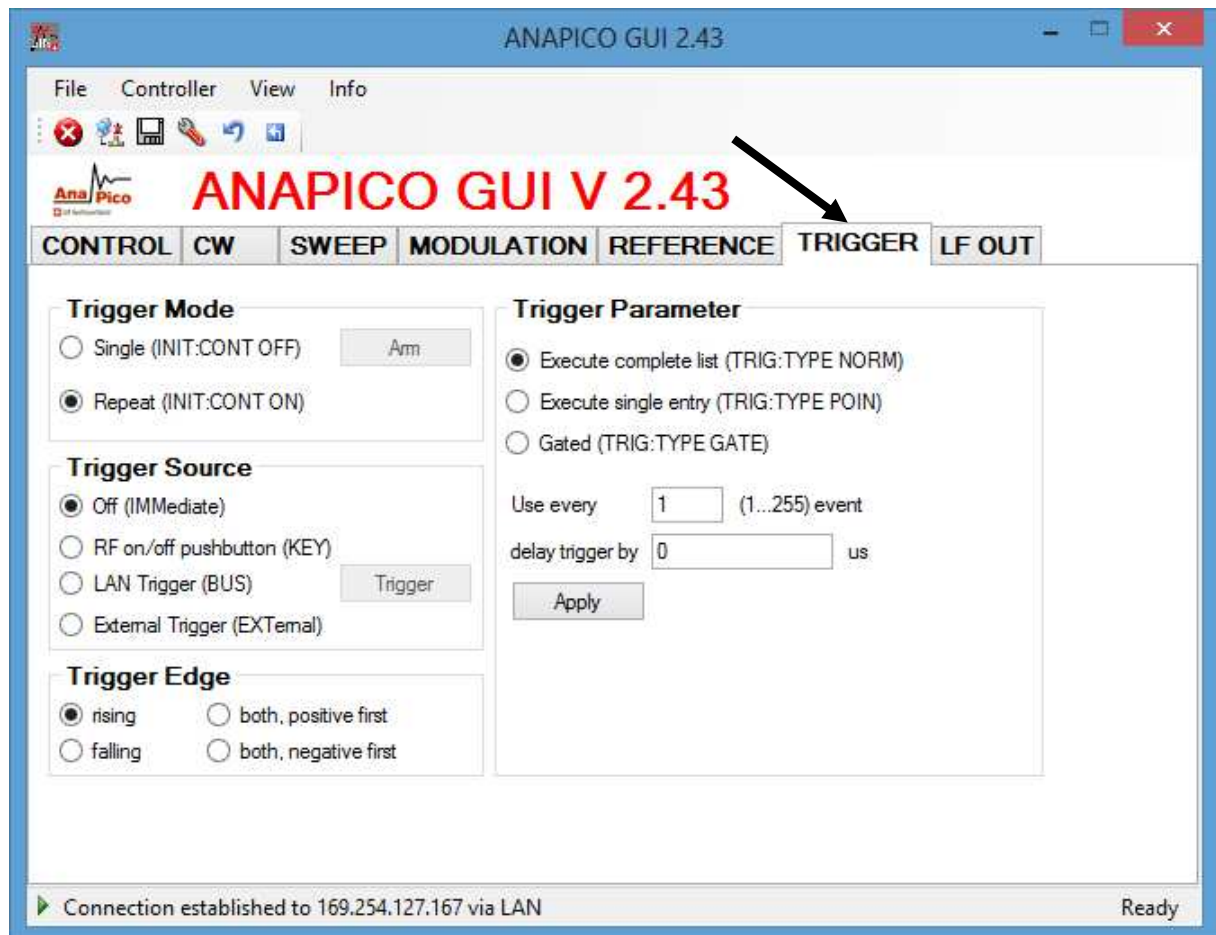

Figure 3-p TRIGGER Tab

3.10 LF OUT Control

The APSIN rear panel output FUNCT OUT can be programmed using the LF OUT tab (see Figure 3-q). The FUNCT OUT output can be used as

- Video output of the internal pulse modulation signal
- Trigger output (see programmer's manual for further configuration)
- Output of one of the low frequency generators

In the GUI select which output to be used and enable it by pressing the ON/OFF button.

The low frequency generator can output sine wave, triangle or a square wave. The frequency can be set from 1 Hz to 5 MHz. The amplitude of the sine wave and triangle can be set for the sine wave and the triangle. If square wave is selected, the output is not affected by the amplitude settings and gives constant 5 Volts peak-peak amplitude.

The output impedance for sine and triangle wave output is 50 ohms, for square wave, trigger and pulse modulation video it is high impedance (CMOS and TTL logic compatible).

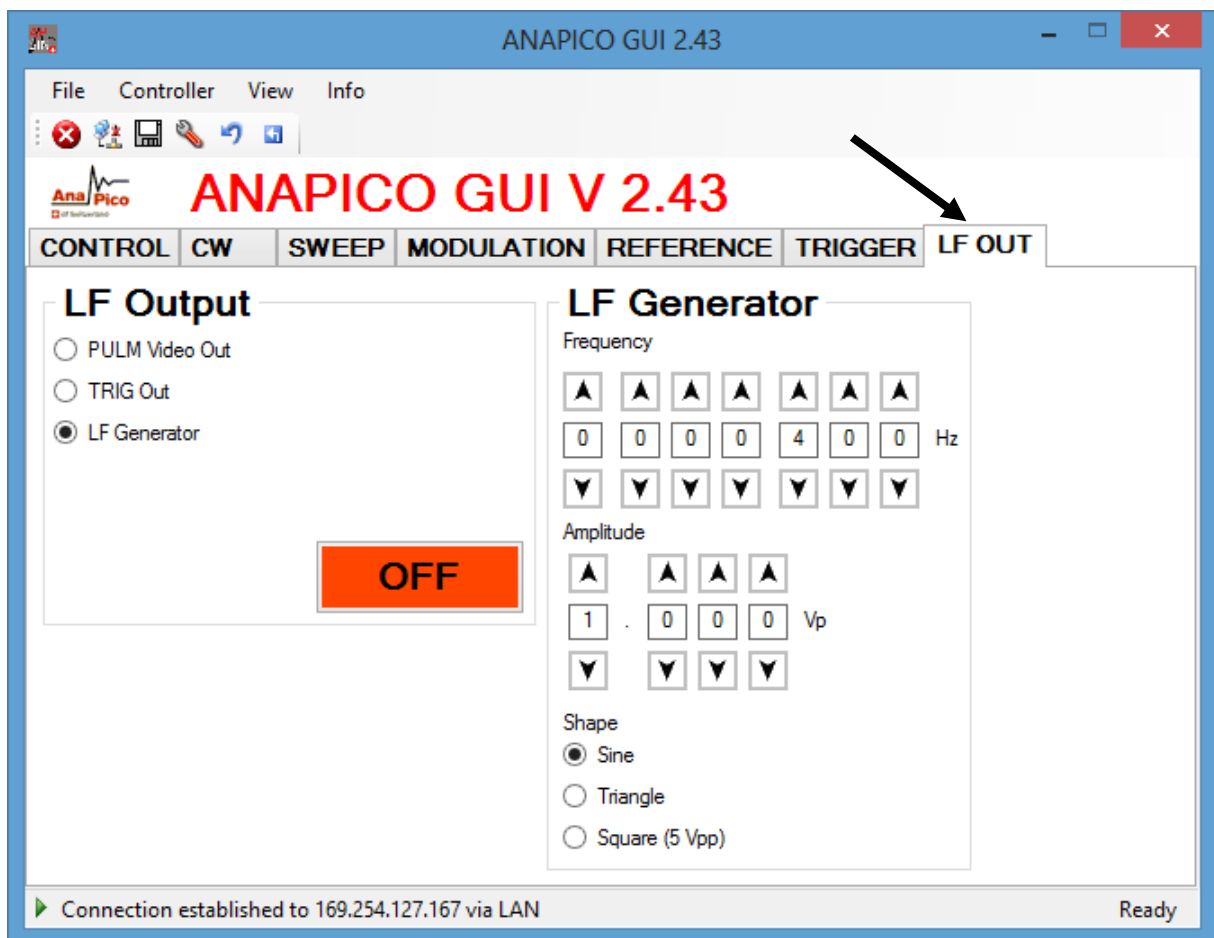

Figure 3-q LF OUT Tab

3.11 Combined Modulation

The table below shows what modulation types can be active simultaneously.

All modulations can be combined with frequency and power sweeps. For frequency and phase modulation, some timing restrictions apply. Check programmer's manual for further details.

Table 3-i Possible combinations of internal and external modulation and the internal LF generator output.

	FM/PM INT / EXT	AM INT / EXT	PULSE INT / EXT	LF Generator
FM/PM INTERNAL EXTERNAL		YES / YES YES / YES	YES / YES YES / YES	YES YES
AM INTERNAL EXTERNAL			NO/ NO NO/ NO	NO YES
PULSE INTERNAL EXTERNAL				YES YES
LF Generator				
CHIRP	NO/NO	YES/YES	YES/YES	YES

Notes:

4 Local Operation via Front Panel

Most of the signal generator models offer direct front panel control.

A rotary knob and five keys (MENU, and four arrow keys) allow full control over the instrument.

Figure 4-a shows the front panel of the APSIN20G.



Figure 4-a APSIN20G Front Panel

RF On/Off button The **ON/OFF** key toggles between RF output on and RF output off. The green light is indicating whether the RF output is enabled (light on) or not.

RF 50Ω connector This female N- type connector provides the output for RF signals. The impedance is 50 ohm. The damage level is +30 dBm maximum. The maximum allowed DC level is +/- 10 V.

Rotary knob is used to switch between menus and to continuously change values at cursor position.

Menu Key This is a multifunction key. The key is used to enter and exit menus. Press once to return to CW menu, press multiple times to toggle between the currently selected submenu and the CW menu.

↓ ↑ → ← Keys These keys are used to move cursor within the screen menus. Within menus, the → ← keys are also used to enter (→) and exit (←) in next menu hierarchy.

LAN LED illuminates as soon a remote connection is active.

Power LED illuminates when system is powered up.

4.1 Displayed Parameter Formats

The following sections describe how to control the instrument via the front panel control by invoking various menu functions.

4.2 CW Display

The Main or CW Display is shown after the instrument has successfully booted and is ready. The four line display has the following format:

Output Frequency	10.100'000'000'0 GHz 
Output Power	+ 10.00 dBm
Ref. Frequency	INT REF FREE-RUN
Remote Control	LAN: 192.168.1.92

The currently active display position is shown by the cursor (underline symbol). The cursor does not move beyond the field of the currently selected parameter. Rotate the front panel knob to modify the value. Clockwise rotation increases the parameter and counter-clockwise rotation decreases the parameter. The parameter value will continue to increase or decrease by the amount of the selected resolution until it reaches the maximum or minimum limit of the parameter.

Use the up and down keys (↓↑) on the front panel to switch between frequency and power. Use the left and right arrow keys (→←) to select the active digit. The resolution step size is selected by positioning the cursor at the appropriate digit and then turning the front panel **rotary knob**.

4.2.1 Main Menu Display

The Main Menu Display is invoked by pressing the **menu key**. The main menu contains eleven submenus as shown below.

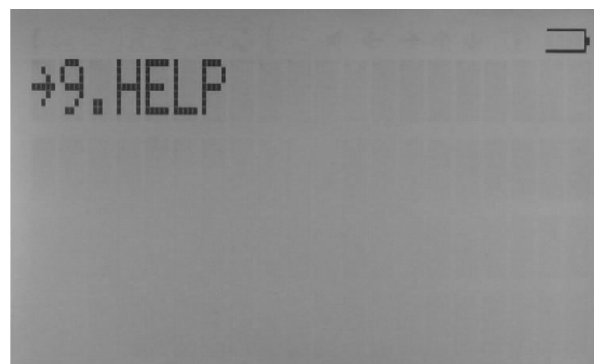
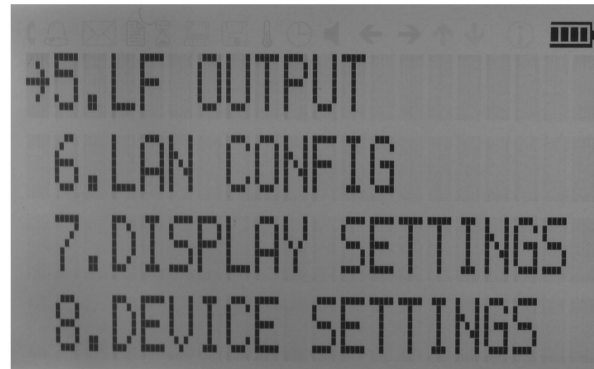
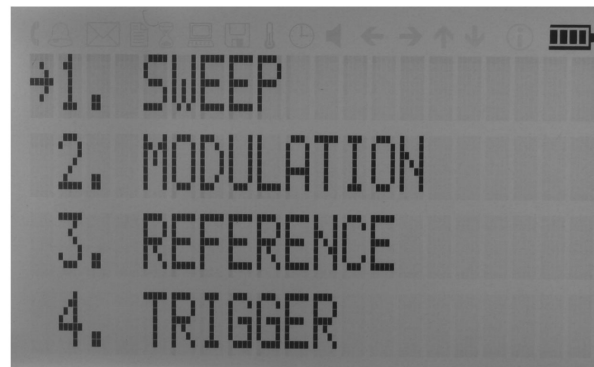

Figure 21 Overview of the submenus available on the display.

Use the up and down arrow keys ($\downarrow \uparrow$) or the **rotary knob** on the front panel to scroll the main menu. The arrow on the left displays the selected position. To enter a submenu, move the arrow (displayed at the left of the menu points) to the desired menu position and press the **menu key**.

4.2.2 Frequency Sweep Submenu

After accessing the Frequency Sweep menu, first of three displays allows to enter the start and stop frequency by using the $\rightarrow \leftarrow$ keys to select the digits and using the **rotary knob** to increase and decrease their values. Use the $\downarrow \uparrow$ arrow to move between the several displays that contain settable sweep parameters. On the second display the number of points and the on and off time can be entered. On the third screen select the sweep mode between LINear, LOGarithmic and RANDom. Also select the repetition mode between INFinite and 1 (single repetition).

Start the sweep by pressing the **RF On/Off button**. The submenus can always be exited (without starting the sweep) by pressing the **menu key**.

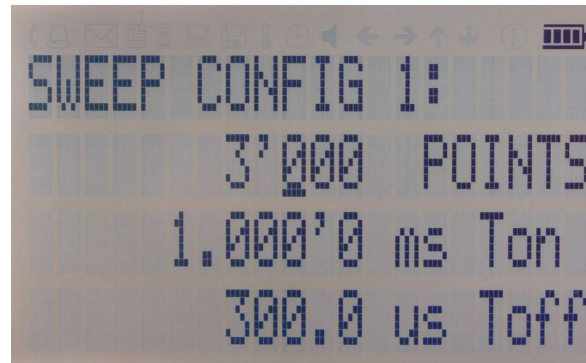
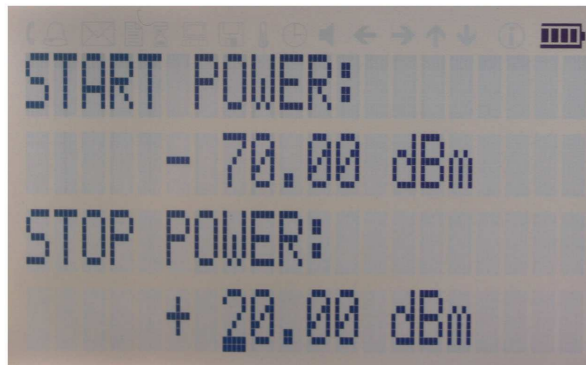

Figure 4-b Displays shown for the frequency sweep configuration

4.2.3 Power Sweep Submenu

After accessing the Power Sweep menu the first of total three displays allow to enter start and stop power by using the → ← keys to select the digits and using the **rotary knob** to increase and decrease their values. Use the ↓ ↑ arrow to move between the several displays that contain settable sweep parameters. On the second display, the number of points and the on and off time can be entered. On the third display, select the repetition mode between INFinite, and 1 (single repetition).

Start the sweep by pressing the **RF On/Off button**. The **submenu can always been exited** (without starting the sweep) by pressing the **menu key**.



Number of Points per Sweep

On (dwell) time

Off time

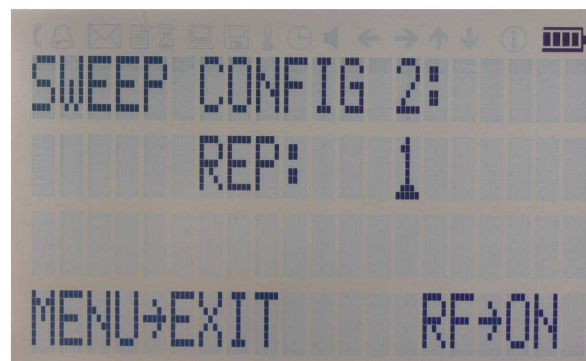

Repetition

Figure 4-c Displays shown for the power sweep configuration

4.2.4 List Sweep Submenu

When entering the List Sweep submenu, a list of stored list sweeps is displayed.

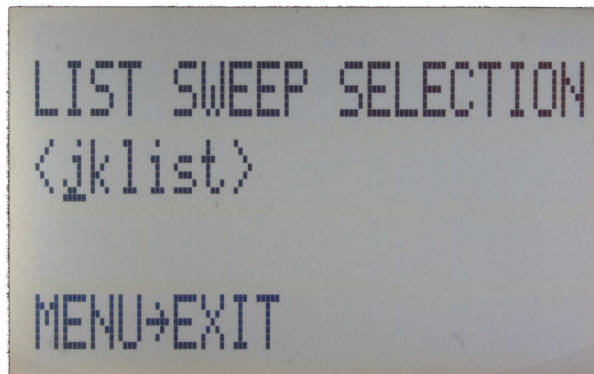

After accessing the List Sweep submenu the first of total two displays allow to enter start and stop power by using the → ← keys to select the digits and using the rotary knob to increase and decrease their values. Use the ↓ ↑ arrow to move between the several displays that contain settable sweep parameters. On the first display the number of repetitions of the list can be entered and the ALC can be set on or off.

On the second display a particular list can be selected from the flash memory of the device.

Start the sweep by pressing the **RF On/Off button**. The submenu can always been exited (without starting the sweep) by pressing the menu key.

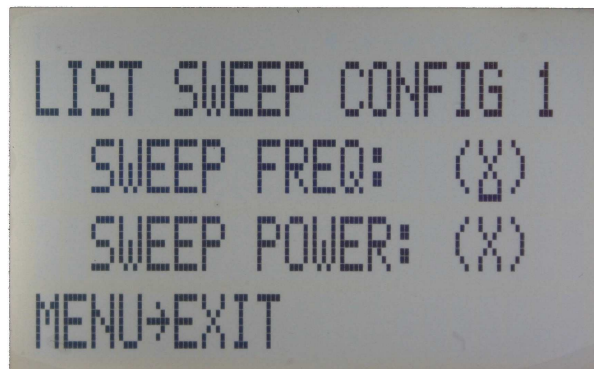

Sweep Freq

Sweep Power

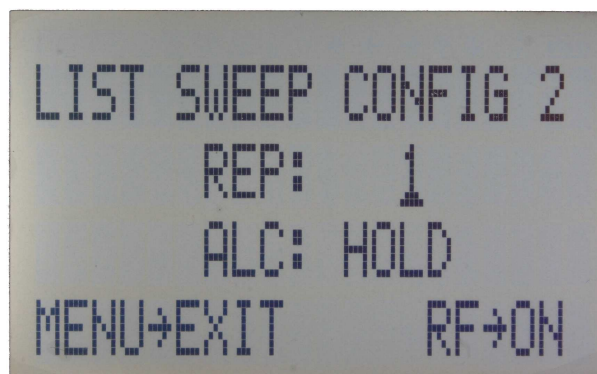

Repetition

ALC on/off/hold

Figure 4-d Displays shown for the list sweep configuration

Important note: All sweeps must be started with the RF on/off button on (green light illuminated) otherwise no signal will be output during the sweep.

4.3 Modulation Submenu

After accessing the Modulation menu, use the ↓↑ arrow keys to select the desired submenu entry. Press the **menu key** to enter the selected submenu. Choose EXIT to return to the main menu.

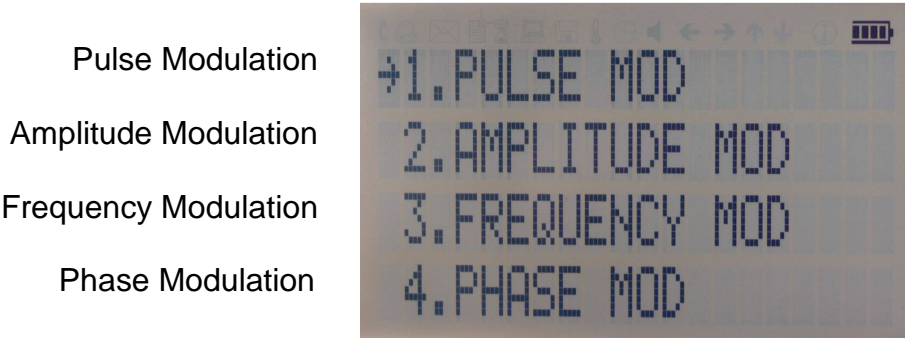

Figure 4-e Modulation Submenu

4.3.1 Pulse Modulation Submenu

In the Pulse Mod submenu the pulse modulation can be accessed. Use the ↓↑ arrow keys to move the cursor to the parameter that you want to change. Use the arrows →← and **rotary knob** to modify the parameters.

On line 1 select between INT (internal pulse generator) and EXT (external input).

If internal modulation (INT) is selected, go to line 2 to change pulse width to desired value and go to line 3 to change pulse modulation frequency.

Enable modulation by pressing the **RF On/Off button**.

Exit the submenu by pressing the **menu key**.

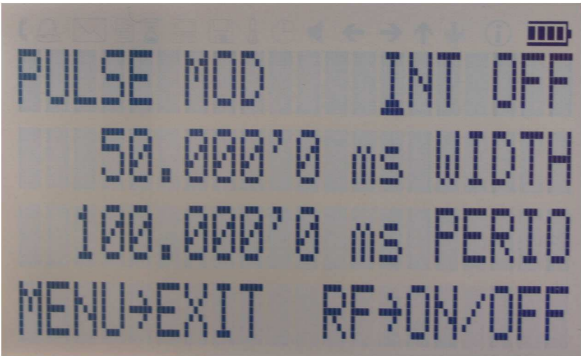

Figure 4-f Pulse Modulation Submenu

4.3.2 Amplitude Modulation Submenu

In the Amplitude Mod submenu the internal amplitude modulation can be accessed. Use the **rotary knob** to set the modulation rate between 1 Hz and 10 kHz.

Enable modulation by pressing the **RF On/Off button**.

Exit the submenu by pressing the **menu key**.

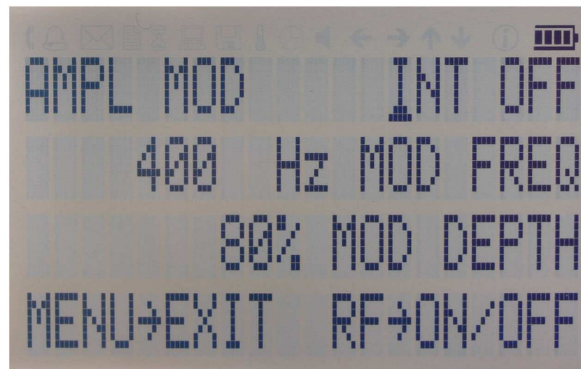

Figure 4-g Amplitude Modulation Submenu

4.3.3 Frequency Modulation Submenu

In the frequency modulation submenu the internal and external frequency modulation can be accessed. Use cursor keys to change between internal and external modulation source and change modulation parameters such as modulation rate, depth or sensitivity. Enable modulation by pressing the **RF On/Off button**.

Exit the submenu by pressing the **menu key**.

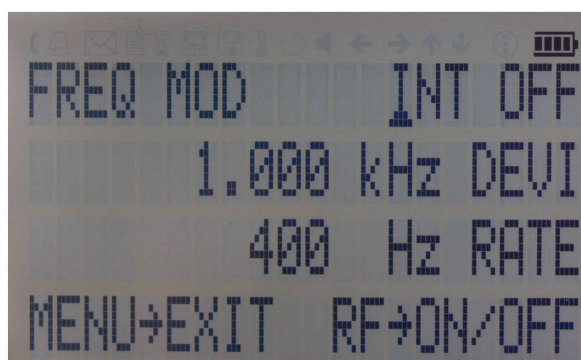
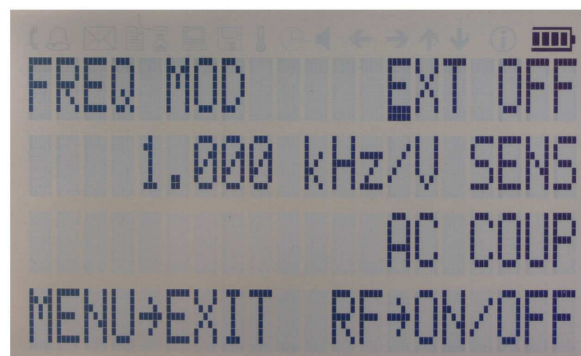

Figure 4-h Frequency Modulation Submenu

4.3.4 Phase Modulation Submenu

In the phase modulation submenu the internal and external phase modulation can be accessed. Use cursor keys to change between internal and external modulation source and change modulation parameters. Enable modulation by pressing the **RF On/Off button**.

Exit the submenu by pressing the **menu key**.

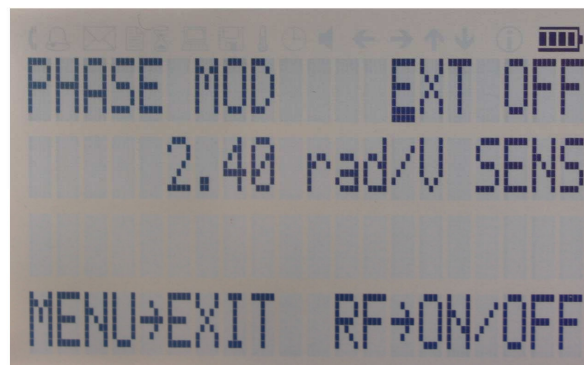
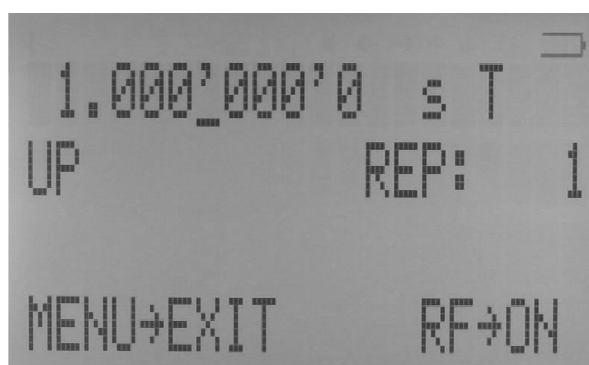
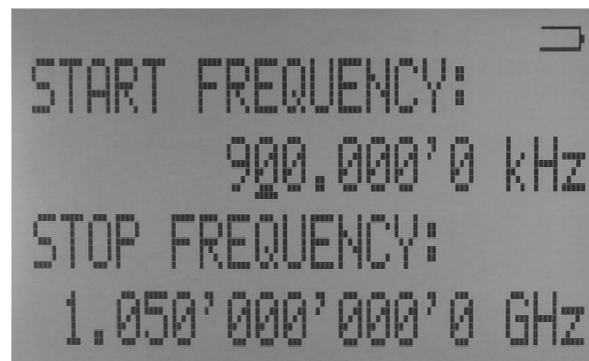

Figure 4-i Phase Modulation Submenu

Chirp



4.4 Reference Submenu

After accessing the Reference menu, use the $\downarrow \uparrow$ arrow keys to move the cursor between the ON/OFF entry and the reference frequency entry. Use the **rotary knob** to toggle between ON and OFF or to change reference frequency to the desired value, respectively. The display shows up as following.

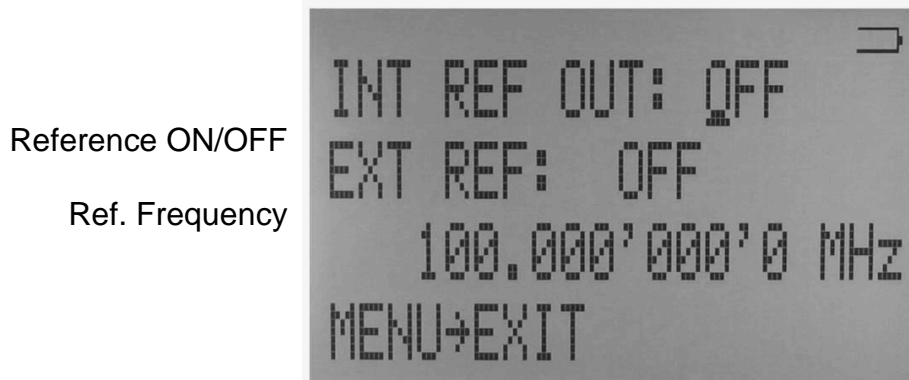

Figure 4-j Reference Submenu

Confirm the setting by exiting the menu (pressing the **menu key**).

4.5 Trigger Submenu

After accessing the Trigger menu, use the $\downarrow \uparrow \rightarrow \leftarrow$ arrow keys to move cursor between the various menu entries. Use the **rotary knob** to toggle the selected entry value or to change selected digit. The display shows up as following.

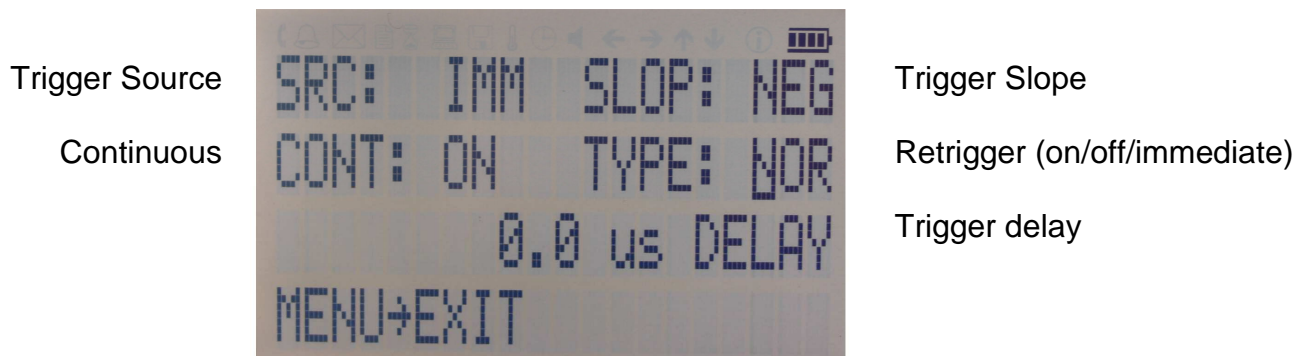

Figure 4-k Trigger Submenu

Select SOURce: IMMEDIATE, EXTernal, BUS (SCPI command), KEY (RF on/off button)

Select SLOPe: POSitive, NEGative

Select CONTinuous: ON, OFF (ON means that the trigger is re-armed after each trigger occurrence)

Select RETRigger: OFF, ON, IMMEDIATE (OFF means that any trigger event during execution of list is ignored)

Enter DELAY: trigger delay in microseconds.

Press the **RF On/Off button** to arm the trigger. Exit the menu by pressing the **menu key**.

4.6 LF OUTPUT Submenu

In the LF OUTPUT Submenu the FUNCT OUT output can be configured at the rear panel of the instrument.

Press the **RF On/Off button** to turn the output on and off. Exit the menu by pressing the **menu key**.

On the first screen the source for the FUNCT OUT can be selected. Choose LFG for the low frequency generator, TRIG to enable the instrument trigger output and PULM to enable the pulse video output. If LFG is selected, use the ↓ arrow to proceed to the second display. Select waveform between sine, triangle, or square. Then enter the desired output frequency and voltage amplitude.

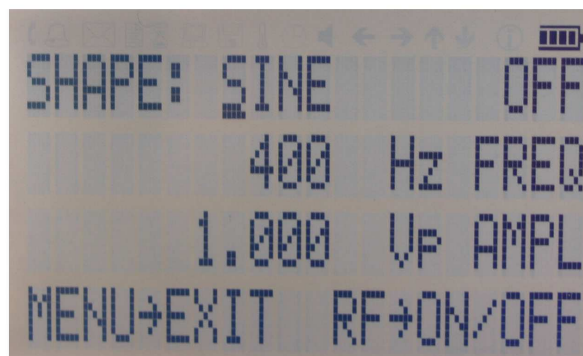
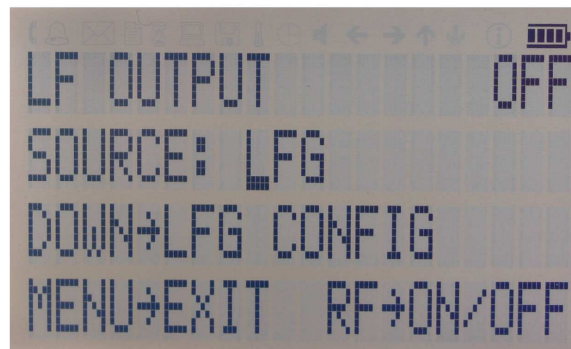

Figure 4-1 Displays shown in the LF OUTPUT Submenu

4.7 LAN Configuration Submenu

After accessing the LAN Configuration menu, use the ↓↑ arrow keys to move cursor between IP address and sub mask address. Use the **rotary knob** to change selected digit. The display shows up as following.

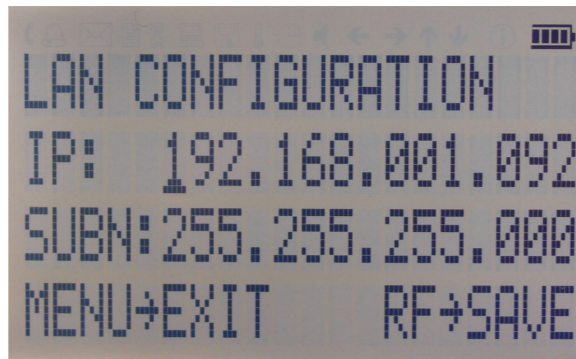

Figure 4-m LAN Configuration Submenu (display 1)

Once you have done changes as required, press the **menu key** to continue the configuration to the second display. The display shows up as shown below:

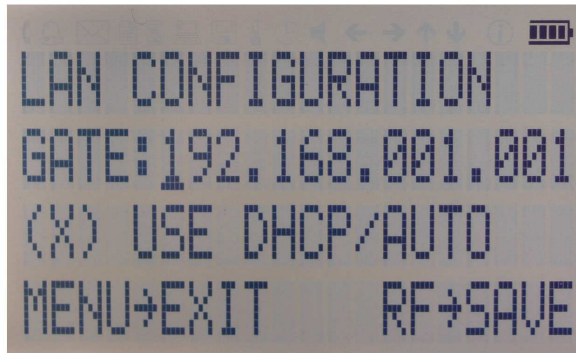

Figure 4-n LAN Configuration Submenu (display 2)

Use keys to change gateway and use the **rotary knob** either enable (X) or disable () DHCP. Press the **RF key** to save the configuration (don't if you want to discard your changes). Press the **menu key** to exit the LAN submenu.

4.8 Display Settings Submenu

After accessing the Display Configuration menu, use the **rotary knob** to change the display contrast as required. Press the **menu key** to save and exit the Display Settings submenu.



Figure 4-o Display settings Submenu

4.9 Settings Submenu

After accessing the Default Configuration menu, use the ↓↑ to select to the desired settings submenu and confirm by **menu key** →.

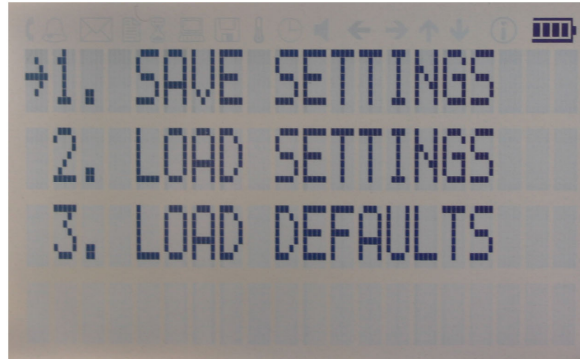

Figure 4-p Default Settings Submenu

4.9.1 Save Settings Submenu

After accessing the Load Settings menu, use the rotary knob to get to the memory state you want to save. Press **RF ON/OFF key** to save your settings. Use ← to return to previous menu or press **menu key** to return to CW.

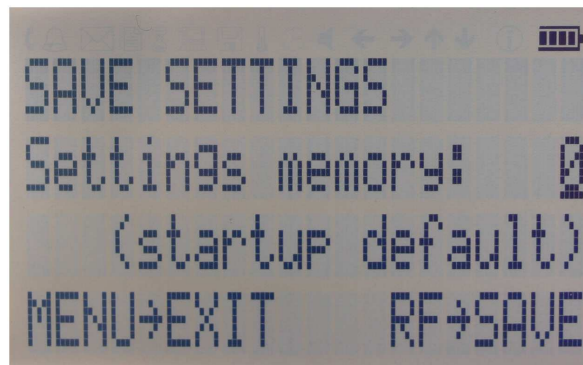

Figure 4-q Save Startup Settings

4.9.2 Load Settings Submenu

After accessing the Load Settings menu, use the rotary knob to get to the memory state you want to load. Press **RF ON/OFF key** to load. Use ← to return to previous menu or press **menu key** to return to CW.



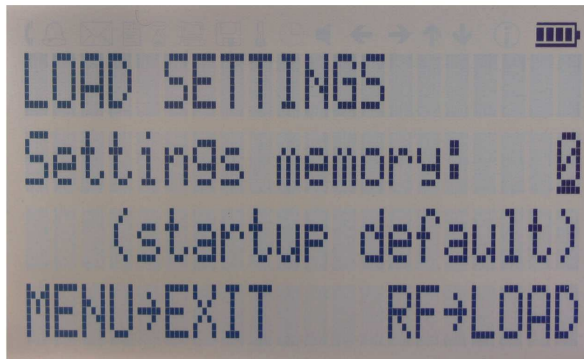

Figure 4-r Load Startup Settings

4.9.3 Load Defaults Submenu

Press **RF ON/OFF key** button to load. Use ← to return to previous menu or press **menu key** to return to CW.

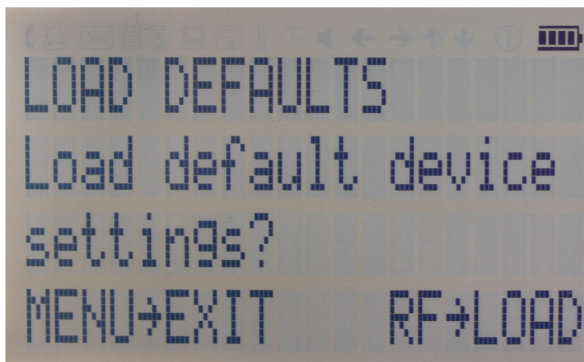

Figure 4-s Restore Startup Settings

4.10 Help Submenu

This submenu provides basic information about the front panel menu control. Exit this menu with ← to return to previous menu or press **menu key** to return to CW.

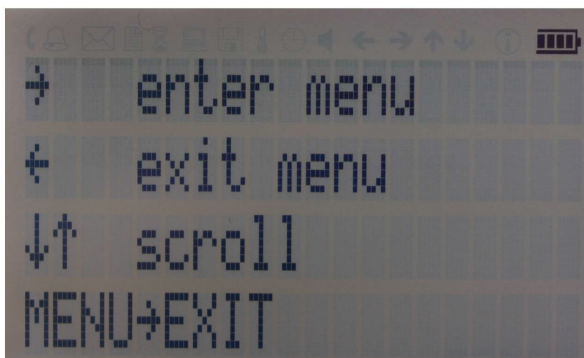

Figure 4-t Help Submenu

5 Remote Programming the APSIN

The signal generator can be remotely programmed. Please refer to the Programmer's Manual for details.

6 Battery Operation (B3 Option)

If your instrument is equipped with an internal rechargeable battery (B3 option) it can be operated without the external power supply. Fully charged battery is good for up to three hours of operation at full RF output power. The same external power adaptor (6 V @ 3 A) is used for the battery version as for the standard model for both normal operation and charging of the battery.

There are four operating modes that are also summarized in Table 2 below:

normal operation – the external power supply is connected to the instrument and the device is turned ON (with the power switch on the rear panel turned ON). In this mode the instrument can be used as if no battery was present. The internal battery is not used and will NOT be charged.

charging – the external power supply is connected to the instrument and the device is turned OFF (with the power switch on the rear panel turned OFF). In this mode the instrument is charging the internal battery. Once the battery is fully charged, the instrument goes into standby mode. Time required to complete charging is approx. four hours.

standby – the internal battery is fully charged and the instrument is turned OFF.

battery operation – the external power supply is disconnected and the device is turned ON. The internal battery is supplying the power until it is exhausted.

Table 2: Operating modes of an instrument equipped with internal battery

External power adaptor Power Switch	supplying power	disconnected
ON	Normal operation (no charging)	Battery operation - until discharged (1)
OFF	Charging – when fully charged → standby (2)	Completely powered off

Notes:

(1) The instrument will switch off automatically when the battery is discharged. It is recommended that the power switch is turned to the OFF position when the battery is fully discharged.

(2) Termination of charging is automatic. The unit will then enter standby mode. The power adaptor can be left connected for any length of time.

During operation the approximate remaining battery capacity is indicated by the battery symbol visible in the upper right corner of the display (see Figure 6-a)

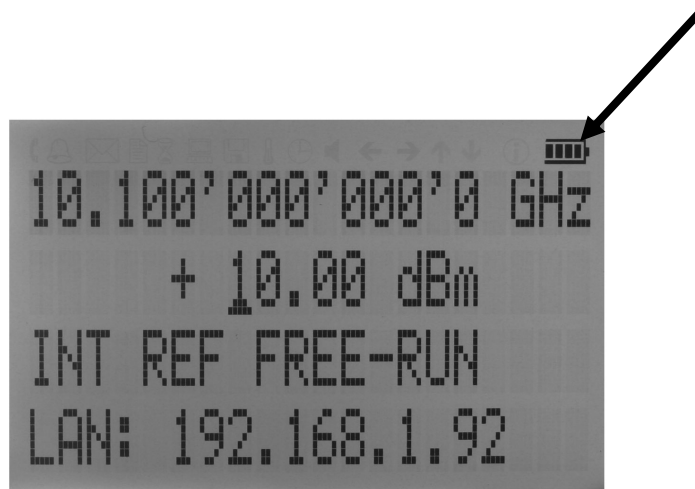

Figure 6-a CW Display with Battery Symbol

Hints for maximizing the battery running time:

1. Fully charge the unit before you use it. Toggle the power switch to ON and then OFF again while the instrument is powered by the external power adaptor. This will initiate a new charge cycle.
2. Charging time of a completely discharged battery can be up to 6 hours. **IMPORTANT: The battery will only be charged when the instrument power switch is in the OFF position.**
3. Batteries should always be charged at room temperature. Charging the instrument at very low or at elevated temperatures may result in early termination of the charging process for example the battery is not fully charged. For safety reasons the charging does not start when the internal temperature of the instrument is above 50 °C.
4. Check the battery indicator in the upper right corner of the display. It should indicate full charge when running on battery power after charging (4 segments).
5. Power consumption of the instrument is reduced when the RF power is switched off thereby increasing overall battery run time.
6. Battery run time is maximal for ambient temperature between 15 and 25 °C. Self-discharge of the battery is much faster at temperatures above 30 °C.
7. Avoid storing the instrument in very hot places such as behind the windshield of a car parked in the sun.

Hints for maximizing battery life expectancy:

1. The battery will reach its best performance after the first few charge-discharge cycles.
2. Always use the external power adaptor supplied with the instrument for normal operation and charging. This will make sure that the charging circuits work as specified.
3. Fully charge the instrument after running it from the battery for an extended period of time.
4. If an instrument with internal battery will be stored for a long period of time, fully charge it before storage, then remove the power adaptor and make sure that the power switch is in the OFF position. After storage, first charge the unit for 4-6 hours.

To replace the battery at the end of its lifetime, please contact our distributor Instruments 4 Engineers.
www.instruments4engineers.com

NOTE:

- ◆ Before using the instrument in battery mode for the first time, the battery must be fully charged.
- ◆ Batteries must be disposed off according to the local environmental regulations.

7 Extended Power Range (PE3 Options)

Some instrument models are available with option PE3 that extends the power range towards lower power levels.

With these options PE3 installed, a mechanical step attenuator module is added. For the guaranteed minimum power level, please consult the respective datasheet.

In sweeps where the mechanical attenuator is switched, the minimum dwell time increases to 20 ms.

8 Maintenance and Warranty Information

8.1 Adjustments and Calibration

To maintain optimum measurement performance, the instrument should be calibrated every 24 months. It is recommended that the instruments be returned to Anapico or to an authorized calibration facility. For more information please contact our Customer Service Department as indicated on www.anapico.com.

8.2 Repair

The signal generator contains no user-serviceable parts. Repair or calibration of the signal generator requires specialised test equipment and must be performed by Anapico or its authorized repair specialists.

8.3 Safety

FCC notice

This equipment has been tested and found to comply with the limits for a Class A device, pursuant to **Part 15 of the FCC Rules**. These limits are designed to provide reasonable protection against harmful interference when the equipment is operated in a commercial environment. This equipment generates, uses, and can radiate radio frequency energy and, if not installed and used in accordance with the instruction manual, may cause harmful interference to radio communications.

Operation of this equipment in a residential area may cause harmful interference in which case the user will be required to correct the interference at his or her expense.



The instrument meets the intent of the **EMC directive 89/336/EEC** and have been designed to **EN61326 Class A Emissions and Immunity** standard.

The instrument also meets the intent of the **Low Voltage Directive** and has been designed to meet the **IEC 61010-1:2001** (safety requirements for electrical equipment, control, and laboratory use) standard.

8.4 Warranty Information

All Anapico instruments are warranted against defects in material and workmanship for a period of **two years** from the date of shipment. AnaPico will, at its option, repair or replace products that prove to be

defective during the warranty period, provided they are returned to AnaPico and provided the preventative maintenance procedures are followed. Repairs necessitated by misuse of the product are not covered by this warranty. No other warranties are expressed or implied, including but not limited to implied warranties of merchantability and fitness for a particular purpose. AnaPico is not liable for consequential damages.

The warranty on the internal rechargeable batteries (option B3) is one year from the date of shipment. Battery replacement is available through AnaPico and its distributors.

8.5 Equipment Returns

For instruments requiring service, either in or out of warranty, contact your local distributor or Anapico Customer Service Department at the address given below for pricing and instructions before returning your instrument.

When you call, be sure to have the following information available:

- Model number.
- Serial number.
- Full description of the failure condition.

Note: Model and serial number can be found on the rear of the instrument, next to the power plug.

You will get a Return Merchandise Authorization (RMA) number from AnaPico, please put it on the outside of the package.

Instruments that are eligible for in-warranty repair will be returned prepaid to the customer. For all other situations the customer is responsible for all shipping charges. An evaluation fee may be charged for processing units that are found to have no functional or performance defects.

For out of warranty instruments, AnaPico will provide an estimate for the cost of repair. Customer approval of the charges will be required before repairs can be made. For units deemed to be beyond repair, or in situations where the customer declines to authorize repair, an evaluation charge may be assessed by Anapico.

Authorized Distributor:



INSTRUMENTS 4 ENGINEERS
Stockport Business & Innovation Centre
3rd Floor Broadstone Mill, Broadstone Road
Stockport, SK5 7DL United Kingdom
Tel: +44 (0) 161 871 7450
Email: Info@instruments4engineers.com